

TEKNIC

CE

INDUSTRIAL PLUGS & SOCKETS



CONTENT

PAGE NO.

INTRODUCTION	01
PRODUCT RANGE OF PLUGS AND SOCKETS	02
QUALITY STANDARDS	06
SPECIFICATIONS OF THE RANGE OF MODELS	11

INTRODUCTION

INDUSTRIAL PLUGS AND SOCKETS IP 44, IP67

Over the past few years TEKNIC has been marketing European Industrial Plugs and Sockets in engineering plastics like polyamide.

TEKNIC has established a cooperation / marketing agreement with SEZ A.S, a well known manufacturer in EU. The present catalogue has been developed to give detailed technical details to customers in India.

With prior experience in Industrial Sockets and plugs, TEKNIC along with their European partners are presenting the latest technological advances to offer the highest level of safety and security of installation.

Having already established satisfied customers in India, TEKNIC is making greater efforts to make the product popular under TEKNIC brand.

The Industrial Plugs and Sockets connecting devices being offered have been designed to connect electrical devices for customers using low voltages in a broad spectrum of human activities in a wide range of Indian Industry.

The range of design being offered is innovative and we have made an attempt to provide detailed information on various problems in this catalog. We hope the customers will find the catalogue quite informative.

PRODUCT RANGE

Diverse, Innovative Product Range of our Industrial Plugs & Sockets

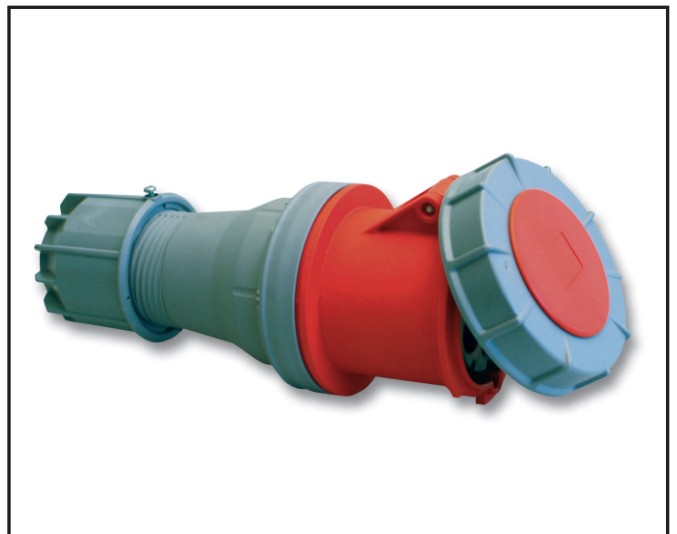

Diverse, Innovative Product Range of our Industrial Plugs & Sockets

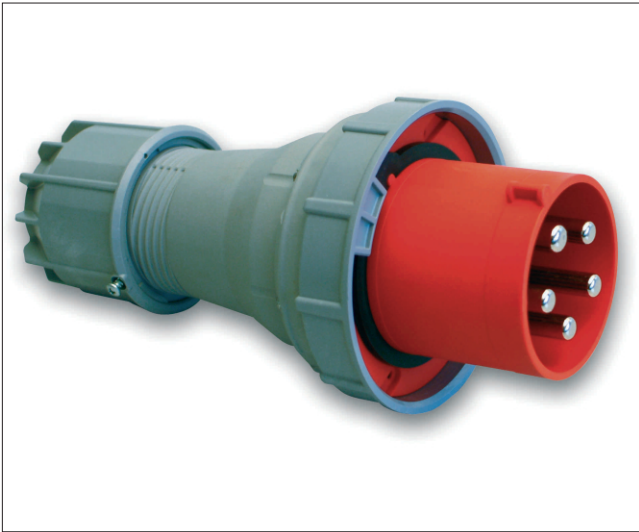

Diverse, Innovative Product Range of our Industrial Plugs & Sockets



Diverse, Innovative Product Range of our Industrial Plugs & Sockets



INDUSTRIAL SOCKETS AND PLUGS

QUALITY STANDARDS:

TEKNIC introduces to India a very modern range of plugs and sockets designed to provide aesthetics, high engineering standards, quality, fair price and prompt supply with after sales service.

INDUSTRIAL PLUGS AND SOCKETS.

Our connecting devices have been designed to connect electrical devices and consumers to low voltage in a broad spectrum of human activities. They are frequently applied in civil engineering, electric assembly sector, engineering industry, chemical and cosmetic industry, pharmaceutical industry and health service, agriculture, food industry, and textile industry, as well as in cinemas, theatres, sports facilities, and holiday resorts.

Sockets and plugs are of circular shape and can be used within the following ranges:

- Nominal current up to 125 A,
- Nominal voltage up to 500 V,
- Nominal frequency of 50 a 60 Hz
- Temperature range between -25°C do $+40^{\circ}\text{C}$. ($\pm 10^{\circ}\text{C}$)

Our sockets, plugs and connectors are manufactured under the STN EN 60309 – 1, 2 norms which comply with European norms EN 60309 – 1, 2 and international standards IEC 60309 – 1, 2.

PRIME QUALITY

The construction of our devices respects the demands of strong reliability and durability as well as the requirements of health protection. We have summarized below the fundamental security principles which will be appreciated by users of our industrial sockets and plugs.

1. Insulation resistance and dielectric strength of the devices must be sufficient

Tests have been carried out to check the fulfilment of these requirements which immediately follow the tests in the humidity chamber or room where the test samples have been adjusted to prescribed temperature, Insulation resistance measured by the unidirectional voltage of approximately 500 V; the measuring begins one minute after the voltage has been applied. The insulation resistance must not be lower than 5 M Ohm. Dielectric strength is measured by the 50 Hz/60 Hz frequency sinusoid voltage of 2000 V (2500 V respectively, for the devices with the nominal voltage of 500 V), which is applied for 1 minute. Neither flash-over nor breakdown must appear during the test.

2. Non-blocked devices must have adequate disconnecting capacity

A plug or a mobile socket is inserted into a built-in socket or a connector and subsequently pulled out with the frequency of 7.5 strokes per minute. The electric contact is maintained for not longer than 4 seconds and not shorter than 2 seconds. There are 50 cycles set for the 16 A and 32 A devices, 20 cycles for 63 A and 125 A devices, respectively. Samples are tested at the 1.1 level of nominal working voltage, and 1.25 level of nominal current values and line current factor 0.6. A persistent arc must not appear during testing.

When tested, the samples must not show any damage that would disable their further operation. Plug pin inlets must not show any serious damage either.

Our 63 A and 125 A sockets and plugs maintain sufficient switching capacity, their electrical blocking by a control (command) contact is therefore unnecessary.

INDUSTRIAL SOCKETS AND PLUGS

3. Normal operation at requirement

The devices must be resistant to the effects of mechanical, electric and heat stress which may appear during normal operation without any excessive wear or other damaging effects. The non-blocked devices tested as described in Point 2 above are further tested as per following cycles:

- Devices 16 A – 5000 cycles under load only;
- Devices 32 A and 63 A – 1000 cycles under load, 1000 cycles unloaded;
- Devices 125 A – 250 cycles under load, 250 cycles unloaded;
- Under load of nominal voltage and line power factor 0.6.

When tested, the samples must not show:

- Any wear preventing further operation of the device, its possible blocking, respectively;
- Any damage of cover or barriers;
- Any damage of plug pin inlets which could cause malfunction;
- Any loosening of electric or mechanical connections.

WARNING:

Disconnecting capacity is required as protection in case of accidental insertion or release of a plug under load. According to STN 33 2180, industrial sockets and plugs are not designed for the operational switching of consumers.

4. Mechanical resistance:

Dismantling devices are equipped with the lightest type of power supply cable of the smallest suitable cross-section. They are then frozen at the temperature of -25°C . Subsequently, the free end of the 2.25 metre-long cable is attached to the wall at 75 cm over the ground. The sample is held so that the cable remains in horizontal position and then dropped onto the concrete floor. The process is repeated eight times, while the cable is twisted at 45° at the point of attachment before each trial.

When tested, the samples must not show any damage, none of the parts must be loosened or separated specially.

5. Heat and combustion resistance:

5.1 Parts made of insulating material are tested by static burden by an appropriate testing device.

The surface of tested parts is placed in horizontal position and a steel ball with 5 mm diameter is pressed into that surface with a force of 20 N.

Testing takes place in a heat chamber at temperatures of:

125°C for parts which carry the live parts of dismantling device;

- 80°C for other parts.

- The ball is removed after one hour and the diameter of the impression is measured. If the material has been deformed, the diameter must not exceed 2 mm.

5.2 The external parts of insulation material and insulation parts which carry the live parts of device must be resistant to excessive heat and combustion. The glow wire test, described in IEC 60695-2-1, is performed to check if this requirement is fulfilled.

INDUSTRIAL SOCKETS AND PLUGS

The temperature of glow wire is :

- 650°C for insulation material parts not needed to keep the conducting parts and protection circuit parts in their position even though they touch them;
- 850°C for insulation material parts needed to keep the conducting parts and protection circuit parts in their position.

The contact lasts 30 seconds. A device passes the glow wire test, if :

- Neither perceivable flame nor permanent heating had appeared; or
- The flame or the heating of the sample or its surroundings ceased within 30 seconds after the glow wire had been removed and the surrounding parts did not burn completely.

6. The Resistance of rubber and thermoplastics to ageing:

The devices with rubber or thermoplastic covers and elastomeric parts, such as joint rings and washers, must show sufficient resistance to ageing which is checked by accelerated Ageing Test in the atmosphere with normal composition and pressure.

The samples hung freely in a heat chamber with the natural circulation of air:

- 70°C and 10 days for rubber;
- 80°C and 7 days for thermoplastic.

The samples are examined after the chamber has been cooled to standard room temperature. No cracks should be visible to the naked eye and the surface must not be sticky or greasy. The samples must not show any damage which would lead to the failure of standard requirements.

Select voltage and work:

The design of the devices ensures that the devices with different working voltages are not interchangeable. The working voltage of a device is determined by the position of the key groove and the protective contact, the so-called hour angle, when the key groove is always in the position of 6 hours. The figure of the hour angle is derived from the position of the protective contact compared to the clock face, the socket being observed from the front.

To prevent faulty connection, the socket is fitted with a key groove, while the plug is fitted with a key. The diameter of protective pin is different from that of phase pin, wrong insertion is therefore completely excluded.

The Installation of sockets and connectors on flammable Surfaces:

To meet the requirements of STN 33 2312, sockets and connectors cannot be installed directly on flammable or easily combustible surfaces. It is necessary to separate them from such surfaces by a non-flammable, heat-insulating panel at least 5 mm thick, protruding at least 10 mm on each side, or they must be installed at least 30 mm distance from the flammable surface, e.g. on consoles.

Dimensioning of connecting terminals:

Socket system IEC (A)	Motor output (Kw)		Connecting terminals to conductor (mm ²)
	400V	500V	
16	7	9	1-2,5 Cu, 1,5-4 Cu/A1*)
32	15	20	2,5-6 Cu 2,5-10 Cu/A1
63	30	40	4-16 Cu 6-25 Cu/A1*)
125	60	80	16-50 Cu 25-70 Cu/A1*)

INDUSTRIAL SOCKETS AND PLUGS

Implementation of innovations in our products:

Of 16 and 32 A devices for voltage of 400 V, IP 44 in 5 and 4-pole version we already produce mobile sockets ISN, plugs IVN, wall sockets IZN, wall connectors IPN and built-in flange sockets IEN (TWIGGY series). The bolts of terminals of the built-in flange sockets are accessible from one direction and when they are installed on the flat wall of the distributor, the conductors can be connected without dismantling of the socket of the distributor.

For our 63 A devices, we have started producing sockets and 5-pole plugs in protection level IP67 shape-adjusted to TWIGGY series, i.e. connecting sockets ISGN, plugs IVGN, wall sockets IZGN, wall connectors IPGN and built-in sockets IEGN. These authentic modification solutions of both the device terminals and the attachments of the connecting cable have been used also in these sockets and plugs.

Reversing adapters RA:

Reversing adapters "RA" 32 A and 16 A acquiring the change of the phase sequence and the adapter "A" from 5-pole socket into a 4-pole socket have been added to the range of our production: Its use is contingent on the symmetric load since the 4-pole socket has the 3P + PE Type of connection.

The straight types of the flange built-in sockets and inlets – IERN, IRRN and IRRNO:

The fixing frames are 75 x 75 mm in size with the distance of 60 x 60 mm among the fixing openings. Terminal components are identical with the sockets and the plugs.

Industrial socket with a box under the plaster – IZV:

The IZV socket will find its scope and use in the tidy-looking interiors above all, where the emphasis is put on the accurate shoulder and a decent presence of industrial sockets. The box embedded in the plaster is common for all of the Types. 6 openings for conductor inputs are situated on the box – 4 of them of oval shape on the side walls and 2 of round shape on the bottom of the box. The boxes can be connected by means of EASY BOND (system (the heart of the EASY BOND system is the connecting element PR-10 and a bolt on the boxes that enables their feeding).













The next part is the cover of the socket, on which an IERN socket is fixed by means of 4 screws. The cover of the socket along with the IERN socket is being fixed on the box. The cap is fixed on the cover by means of its offsets and it closes by use of two spiral springs. The outer parameters of the cover of the box and of the cap are identical for all types. The outer surface of the cap has the features of TWIGGY socket caps. The range of our supplies covers 16 A, 32 A and 4 pole and 5-pole versions.

Combined socket IZVZ:

Our new product with type designation IZVZ combines 400 V and 230 V socket in itself. It finds its use in all the cases when the situation calls for a simultaneous connection of a single-phase and three-phase device. Special emphasis is put on the electric capability, safety and user-friendliness in course of the development of the device. IZVZ is supplied in the market with the cover of IP44 and in versions 16 A 4P (IZVZ 1643), 16 A 5P (IZVZ 1653). The 32-ampere variants (IZVZ 3243, IZVZ 3253) are delivered with a case switch fuse 16 A for single phase 230 V/16 A socket safety.

INDUSTRIAL SOCKETS AND PLUGS

Symbols used in the catalogue:

-  Connection: **2P + PE**; hour angle of socket: **6 hours**; colour: **blue**
-  Connection: **3P + PEN**; hour angle of socket: **6 hours**; colour: **red**
-  Connection: **3P + N + PE**; hour angle of socket: **6 hours**; colour **red**
-  Connection: **3P + PEN**; hour angle of socket: **7 hours**; colour: **black**
-  Connection: **3P + N + PE**; hour angle of socket: **6 hours**; the option of changing the sequence of phases; colour: **red**
-  Connection: **2P + PE**; hour angle of socket: **6 hours**; colour: **blue**; **with a pilot contact**
-  Connection: **3P + PEN**; hour angle of socket: **6 hours**; colour: **red**; **with a pilot contact**
-  Connection: **3P + N + PE**; hour angle of socket: **6 hours**; colour: **red**; **with a pilot contact**
-  Connection: **3P + PEN**; hour angle of socket: **7 hours**; colour: **black**; **with a pilot contact**
-  Connection: **3P + N + PE**; hour angle of socket: **7 hours**; colour: **black**; **with a pilot contact**
-  Connection: **2P + PE**; farba: **modrá**
-  Connection: **2P + PE**; farba: **modrá**

IP 44 Device with the degree of protection **IP 44** Device with the degree of protection **IP 67**

TEKNIC

INDUSTRIAL SOCKETS AND PLUGS

**SPECIFICATIONS
OF THE RANGE OF MODELS**

TEKNIC

INDUSTRIAL SOCKETS AND PLUGS

SPECIFICATIONS

Current [A]	Voltage [V]	Pole / hour angle	Type	Connecting socket	ISN – Twiggy
-------------	-------------	-------------------	------	-------------------	--------------

IP 44

16 400  ISN 1643

16 400  ISN 1653

32 400  ISN 3243

32 400  ISN 3253

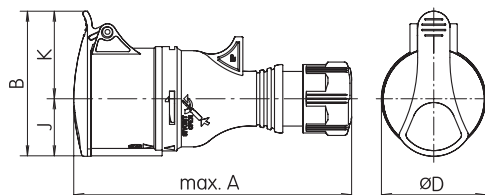

Type \ [mm]	A	B	ØD	J	K
ISN 1643	171	81,5	56	31,5	50
ISN 1653	171	89	64	35	54
ISN 3243	200	96	65	38	58
ISN 3253	200	103	73	41	62

16 230  IS 1632

16 400  IS 1643

16 400  IS 1653

16 500  IS 1645

32 230  IS 3232

32 400  IS 3243

32 400  IS 3253

32 500  IS 3245

Connecting socket IS

IP 44

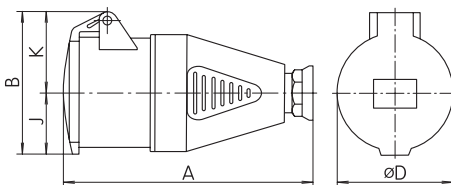

Type \ [mm]	A	B	ØD	J	K	Pg
IS 1632	132	73,5	57	31,5	42	16
IS 164x	137	80	63	35	45	16
IS 1653	137	86	69	40	46	16
IS 3232	165	93	72	42	51	21
IS 324x	165	93	72	42	51	21
IS 3253	165	98	78	45	53	21

16 230  ISG 1632

16 400  ISG 1643

16 400  ISG 1653

32 230  ISG 3232

32 400  ISG 3243

32 400  ISG 3253

Connecting socket ISG

IP 67

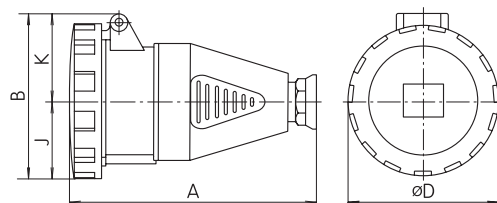

Type \ [mm]	A	B	ØD	J	K	Pg
ISG 1632	136	78,5	70	35	43,5	16
ISG 1643	142	85,5	78	39	46,5	16
ISG 1653	145	92,5	87	43,5	49	16
ISG 3232	166	101,5	93	46,5	55	21
ISG 3243	166	101,5	93	46,5	55	21
ISG 3253	168	108	100	50	58	21

Connecting socket ISGN – Twiggy

IP 67

63 400  ISGN 6353

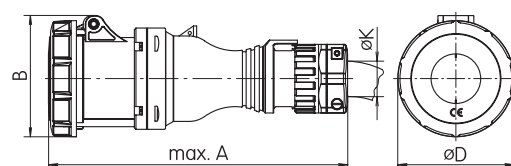

Type \ [mm]	A	B	ØD	ØK
ISGN 6353	285	115	110	32

INDUSTRIAL SOCKETS AND PLUGS

Current [A]	Voltage [V]	Pole / hour angle	Type	Connecting socket ISGN
-------------	-------------	-------------------	------	------------------------

IP 67

125 230  ISGN 12532

125 400  ISGN 12543

125 400  ISGN 12553

125 500  ISGN 12545

125 500  ISGN 12555

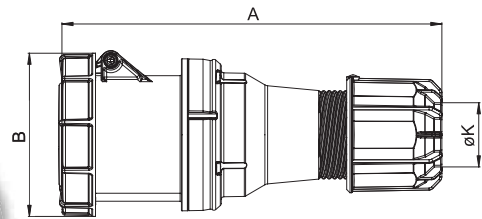

Type \ [mm]	A	B	øK
ISGN 12532	269	114	22,5-50
ISGN 12543	269	114	22,5-50
ISGN 12553	269	114	22,5-50
ISGN 12545	269	114	22,5-50
ISGN 12555	269	114	22,5-50

125 230  ISGN 12532-p

125 400  ISGN 12543-p

125 400  ISGN 12553-p

125 500  ISGN 12545-p

125 500  ISGN 12555-p

Connecting socket ISGN with a pilot contact

IP 67

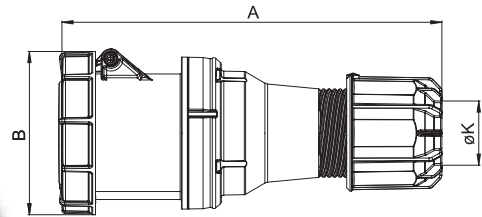

Type \ [mm]	A	B	øK
ISGN 12532-p	269	114	22,5-50
ISGN 12543-p	269	114	22,5-50
ISGN 12553-p	269	114	22,5-50
ISGN 12545-p	269	114	22,5-50
ISGN 12555-p	269	114	22,5-50

63 400  ISG 6343

63 500  ISG 6345

Connecting socket ISG

IP 67

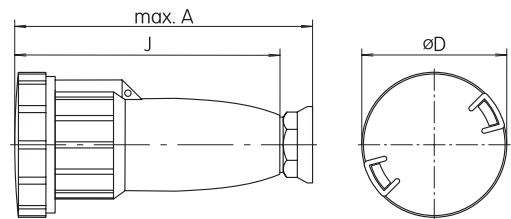
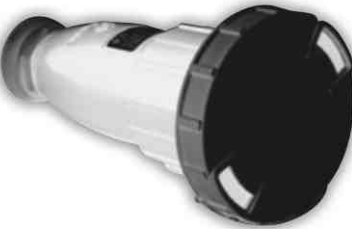

Type \ [mm]	max. A	D	J	Pg
ISG 6343	224	113	196	P29
ISG 6345	224	113	196	P29

16 400  IVN 1643

16 400  IVN 1653

32 400  IVN 3243

32 400  IVN 3253

Plug IVN – Twiggy

IP 44

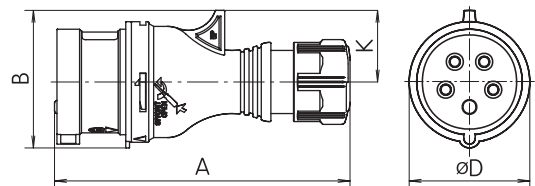

Type \ [mm]	A	B	ØD	K
IVN 1643	157	64	64	34
IVN 1653	157	67	64	38
IVN 3243	190	74,5	73	40,5
IVN 3253	190	77	73	45

INDUSTRIAL SOCKETS AND PLUGS

Current [A]	Voltage [V]	Pole / hour angle	Type	Reversing plug IVNO – Twiggy
-------------	-------------	-------------------	------	------------------------------

IP 44

16 400  IVNO 1653

32 400  IVNO 3253

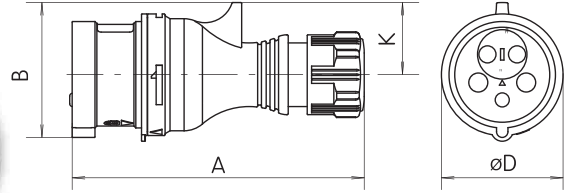

Type \ [mm]	A	B	ØD	K
IVNO 1653	157	67	64	38
IVNO 3253	190	77	73	45

16 230  IV 1632

16 400  IV 1643

16 400  IV 1653

16 500  IV 1645

32 230  IV 3232

32 400  IV 3243

32 400  IV 3253

32 500  IV 3245

Plug IV

IP 44

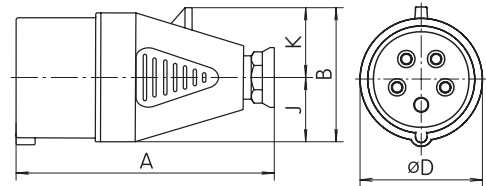
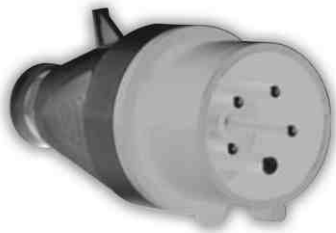

Type \ [mm]	A	B	ØD	J	K	Pg
IV 1632	123	59,5	57	28,5	31	P16
IV 164x	129	67,5	65	32,5	35	P16
IV 1653	129	71,5	65	32,5	39	P16
IV 3232	154	77	72	36	41	P21
IV 324x	154	77	72	36	41	P21
IV 3253	154	82	78	36	46	P21

Plug IV

IP 44

63 400  IV 6343

63 500  IV 6345

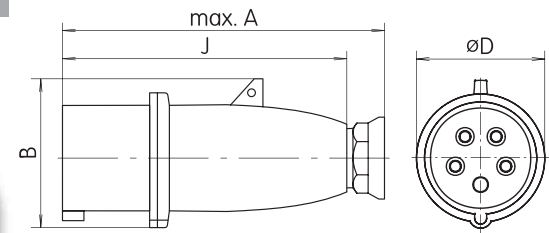
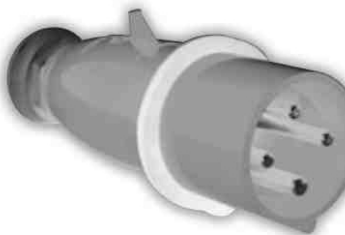

Type \ [mm]	A	B	ØD	J	Pg
IV 6343	213	95	83	184	P29
IV 6345	213	95	83	184	P29

16 230  IVG 1632

16 400  IVG 1643

16 400  IVG 1653

32 230  IVG 3232

32 400  IVG 3243

32 400  IVG 3253

Plug IVG

IP 67

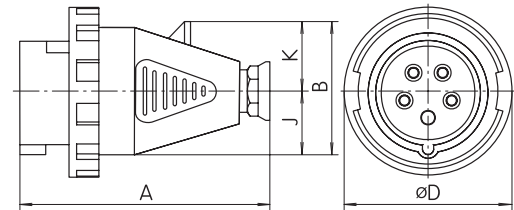
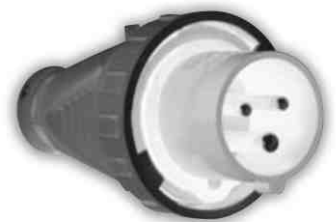

Type \ [mm]	A	ØD	J	K	Pg
IVG 1632	123	70	28,5	31	P16
IVG 1643	129	78	32,5	35	P16
IVG 1653	129	87	32,5	39	P16
IVG 3232	154	92,5	36	41	P21
IVG 3243	154	92,5	36	41	P21
IVG 3253	154	100	36	46	P21

INDUSTRIAL SOCKETS AND PLUGS

Current [A]	Voltage [V]	Pole / hour angle	Type	Plug IVGN – Twiggy
-------------	-------------	-------------------	------	--------------------

IP 67

63 400  IVGN 6353

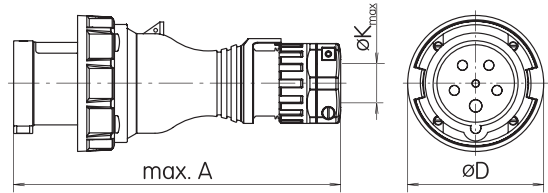

Type \ [mm]	A	ØD	ØK
IVGN 6353	265	110	32

125 230  IVGN 12532

Plug IVGN

IP 67

125 400  IVGN 12543

125 400  IVGN 12553

125 500  IVGN 12545

125 500  IVGN 12555

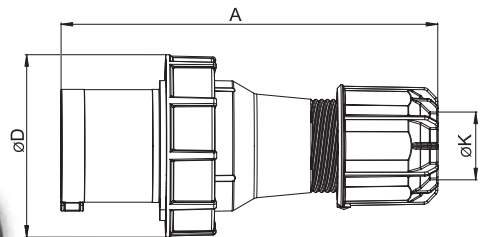

Type \ [mm]	A	ØD	ØK
IVGN 12532	270	131	22,5-50
IVGN 12543	270	131	22,5-50
IVGN 12553	270	131	22,5-50
IVGN 12545	270	131	22,5-50
IVGN 12555	270	131	22,5-50

63 400  IVG 6343

Plug IVG, CVG

IP 67

63 500  IVG 6345

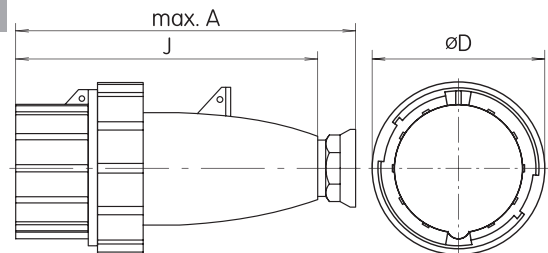
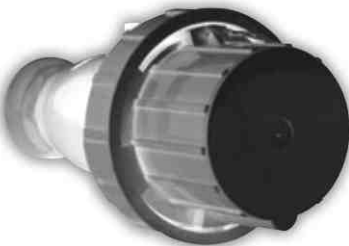

Type \ [mm]	A	ØD	J	Pg
IVG 6343	224	113	195	P29
IVG 6345	224	113	195	P29

16 400  IZN 1643

Wall socket IZN

IP 44

16 400  IZN 1653

32 400  IZN 3243

32 400  IZN 3253

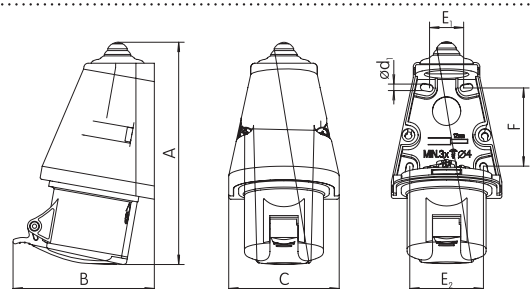

Type \ [mm]	A	B	C	Ød	E ₁	E ₂	F
IZN 1643	157	99	78	4	30	53	58
IZN 1653	157	104	78	4	30	53	58
IZN 3243	179	118	88	4	35	61	60
IZN 3253	179	121	88	4	35	61	60

INDUSTRIAL SOCKETS AND PLUGS

Current [A]	Voltage [V]	Pole / hour angle	Type	Wall socket IZS
16	230		IZS 1632	
16	400		IZS 1643	
16	400		IZS 1653	
16	500		IZS 1645	
32	230		IZS 3232	
32	400		IZS 3243	
32	400		IZS 3253	
32	500		IZS 3245	

IP 44

Type \ [mm]	A	B	C	ød ₁	E	I	Pg	Modification
IZS 1632	129	85	66	4,4	53	25	P13,5	A
IZS 164x	134	87	75	5,2	60	29,5	P16	A
IZS 1653	154	88,5	75	5,2	60	29,5	P16	B
IZS 3232	155	101	82	5,2	67	34	P21	A
IZS 324x	155	101	82	5,2	67	34	P21	A
IZS 3253	179	103	82	5,2	67	34	P21	B

Current [A]	Voltage [V]	Pole / hour angle	Type	Wall socket IZ
63	400		IZ 6343	
63	500		IZ 6345	

IP 44

Type \ [mm]	A	B	C	ød ₁	E	I	L	Pg
IZ 6343	221	132	132	7	114	90,3	180,6	P36
IZ 6345	221	132	132	7	114	90,3	180,6	P36

Current [A]	Voltage [V]	Pole / hour angle	Type	Combined socket IZVZ
16	400		IZVZ 1643	
16	400		IZVZ 1653	
32	400		IZVZ 3243	
32	400		IZVZ 3253	

IP 44 IZVZ 32xx contains a fuse 16A.

Type \ [mm]	A	B	C
IZVZ 16xx	182	113	90
IZVZ 32xx	193	118	90

Current [A]	Voltage [V]	Pole / hour angle	Type	Wall socket IZG
16	230		IZG 1632	
16	400		IZG 1643	
16	400		IZG 1653	
32	230		IZG 3232	
32	400		IZG 3243	
32	400		IZG 3253	

IP 67

Type \ [mm]	A	B	D	ød ₁	E	I	Pg
IZG 1632	146	90	78,5	4,8	65,6	32	P16
IZG 1643	148	92	78,5	4,8	65,6	32	P16
IZG 1653	148	96	87	4,8	65,6	32	P16
IZG 3232	173	111	92,5	5,2	71	35,5	P21
IZG 3243	173	111	92,5	5,2	71	35,5	P21
IZG 3253	175	114	100	5,2	71	35,5	P21

INDUSTRIAL SOCKETS AND PLUGS

Current [A]	Voltage [V]	Pole / hour angle	Type	Wall socket IZGN – Twiggy
-------------	-------------	-------------------	------	---------------------------

IP 67

63 400  IZGN 6353

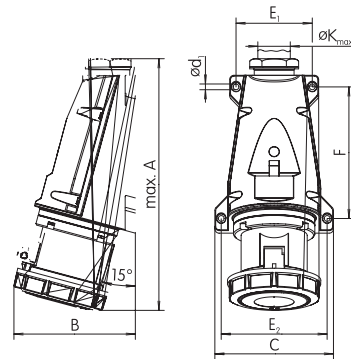

Type \ [mm]	A	B	C	ød ₁	E ₁	E ₂	F	øK
IZGN 6353	300	145	140	6,5	90	125	155	35

125 230  IZGN 12532

Wall socket IZGN

IP 67

125 400  IZGN 12543

125 400  IZGN 12553

125 500  IZGN 12545

125 500  IZGN 12555

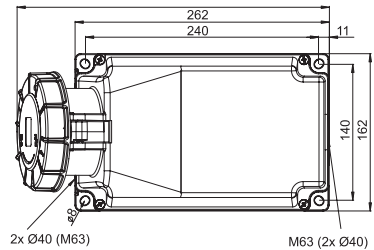
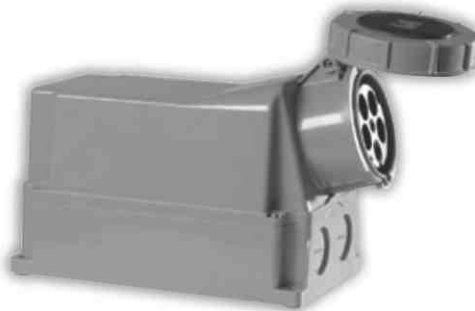

Type \ [mm]	A	B=height
IZGN 12532	322	205
IZGN 12543	322	205
IZGN 12553	322	205
IZGN 12545	322	205
IZGN 12555	322	205

125 230  IZGN 12532-p

Wall socket IZGN with a pilot contact

IP 67

125 400  IZGN 12543-p

125 400  IZGN 12553-p

125 500  IZGN 12545-p

125 500  IZGN 12555-p

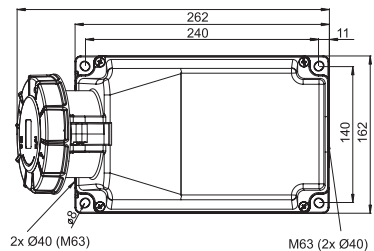
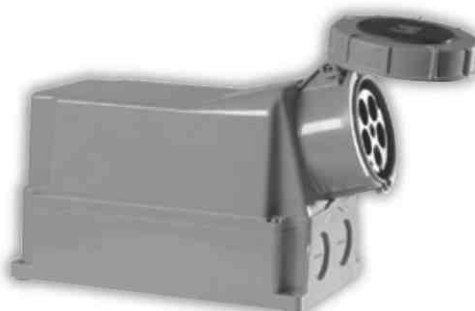

Type \ [mm]	A	B=height
IZGN 12532-p	322	205
IZGN 12543-p	322	205
IZGN 12553-p	322	205
IZGN 12545-p	322	205
IZGN 12555-p	322	205

Wall socket IZG

IP 67

63 400  IZG 6343

63 500  IZG 6345

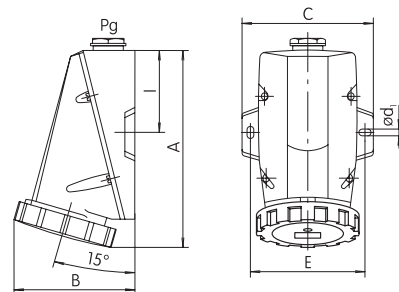

Type \ [mm]	A	B	C	ød ₁	E	I	Pg
IZG 6343	225	131	132	7	114	90,3	P36
IZG 6345	225	131	132	7	114	90,3	P36

INDUSTRIAL SOCKETS AND PLUGS

Current [A]	Voltage [V]	Pole / hour angle	Type	Wall inlet IPN – Twigg
IP 44				
16	400		IPN 1643	
16	400		IPN 1653	
32	400		IPN 3243	
32	400		IPN 3253	

Type \ [mm]	A	B	C	$\varnothing d_1$	E ₁	E ₂	F
IPN 1643	146	81	78	4	30	53	58
IPN 1653	146	81	78	4	30	53	58
IPN 3243	168	95	88	4	35	61	60
IPN 3253	168	95	88	4	35	61	60

Current [A]	Voltage [V]	Pole / hour angle	Type	Reversing wall inlet IPNO – Twigg
IP 44				
16	400		IPNO 1653	
32	400		IPNO 3253	

Type \ [mm]	A	B	C	$\varnothing d_1$	E ₁	E ₂	F
IPNO 1653	146	81	78	4	30	53	58
IPNO 3253	168	95	88	4	35	61	60

Current [A]	Voltage [V]	Pole / hour angle	Type	Wall inlet IP
IP 44				
16	230		IP 1632	
16	400		IP 1643	
16	400		IP 1653	
16	500		IP 1645	
32	230		IP 3232	
32	400		IP 3243	
32	400		IP 3253	
32	500		IP 3245	

Type \ [mm]	A	B	C	$\varnothing d_1$	E	I	Pg	Modification
IP 1632	119	89	66	4,4	53	25	P13,5	A
IP 164x	126	90,5	75	5,2	60	29,5	P16	A
IP 1653	126	92	75	5,2	60	29,5	P16	B
IP 3232	147	105	82	5,2	67	34	P21	A
IP 324x	147	105	82	5,2	67	34	P21	A
IP 3253	147	105	82	5,2	67	34	P21	B

Current [A]	Voltage [V]	Pole / hour angle	Type	Wall inlet IPG
IP 67				
16	400		IPG 1643	
16	400		IPG 1653	
32	400		IPG 3243	
32	400		IPG 3253	

Type \ [mm]	A	B	$\varnothing d_1$	$\varnothing D$	E	F	I	Pg
IPG 1643	143	92	5,2	78	50	30	18	P16
IPG 1653	143	98	5,2	87	50	30	18	P16
IPG 3243	165	108	5,2	92,5	58	40	20	P21
IPG 3253	165	113	5,2	100	58	40	20	P21

INDUSTRIAL SOCKETS AND PLUGS

Current [A]	Voltage [V]	Pole / hour angle	Type	Wall inlet CPG
-------------	-------------	-------------------	------	----------------

IP 67

16 230  CPG 1632

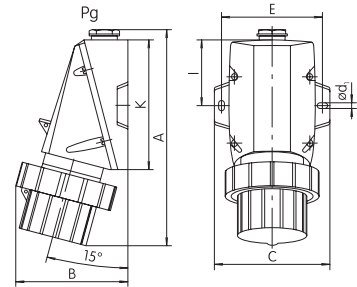

Type \ [mm]	A	B	C	Ød ₁	E	I	K	Pg
CPG 1632	170	83	86	4,8	74	50,7	101,4	P16

Wall inlet IPGN – Twiggy

IP 67

63 400  IPGN 6353

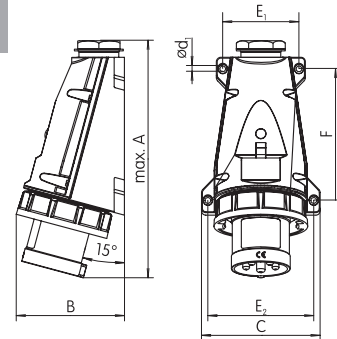
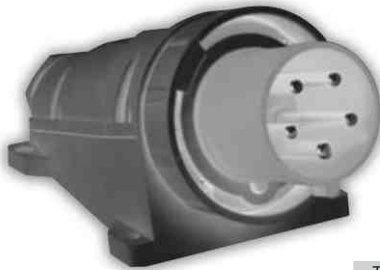

Type \ [mm]	A	B	C	Ød ₁	E ₁	E ₂	F	K
IPGN 6353	280	130	140	6,5	90	125	155	35

125 230  IPGN 12532

Wall inlet IPGN

IP 67

125 400  IPGN 12543

125 400  IPGN 12553

125 500  IPGN 12545

125 500  IPGN 12555

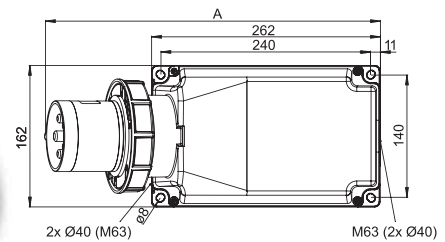

Type \ [mm]	A	B=height
IPGN 12532	387	209
IPGN 12543	387	209
IPGN 12553	387	209
IPGN 12545	387	209
IPGN 12555	387	209

Wall inlet IPG

IP 67

63 400  IPG 6343

63 500  IPG 6345

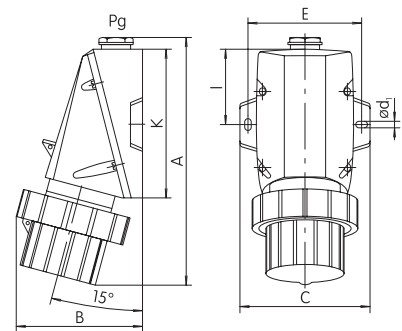

Type \ [mm]	A	B	C	D1	E	I	K	Pg
IPG 6343	260	122	103	7	91,5	72,2	144,5	P29
IPG 6345	260	122	103	7	91,5	72,2	144,5	P29

INDUSTRIAL SOCKETS AND PLUGS

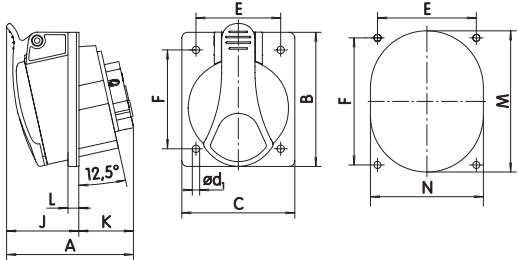
Current [A]	Voltage [V]	Pole / hour angle	Type	Built-in socket IEN – Twiggy																																																												
IP 54																																																																
16	400		IEN 1643	  <table border="1"> <thead> <tr> <th>Type \ [mm]</th> <th>A</th> <th>B</th> <th>C</th> <th>Ød₁</th> <th>J</th> <th>E</th> <th>F</th> <th>K</th> <th>L</th> <th>M</th> <th>N</th> </tr> </thead> <tbody> <tr> <td>IEN 1643</td> <td>73</td> <td>85</td> <td>75</td> <td>5,2</td> <td>42</td> <td>60</td> <td>60</td> <td>31</td> <td>7</td> <td>66</td> <td>58</td> </tr> <tr> <td>IEN 1653</td> <td>75</td> <td>85</td> <td>75</td> <td>5,2</td> <td>43</td> <td>60</td> <td>60</td> <td>32</td> <td>7</td> <td>72</td> <td>64</td> </tr> <tr> <td>IEN 3243</td> <td>90</td> <td>95</td> <td>80</td> <td>5,2</td> <td>52</td> <td>60</td> <td>70</td> <td>38</td> <td>8</td> <td>78</td> <td>68</td> </tr> <tr> <td>IEN 3253</td> <td>92</td> <td>95</td> <td>80</td> <td>5,2</td> <td>53</td> <td>60</td> <td>70</td> <td>39</td> <td>8</td> <td>84</td> <td>70</td> </tr> </tbody> </table>	Type \ [mm]	A	B	C	Ød ₁	J	E	F	K	L	M	N	IEN 1643	73	85	75	5,2	42	60	60	31	7	66	58	IEN 1653	75	85	75	5,2	43	60	60	32	7	72	64	IEN 3243	90	95	80	5,2	52	60	70	38	8	78	68	IEN 3253	92	95	80	5,2	53	60	70	39	8	84	70
Type \ [mm]	A	B	C		Ød ₁	J	E	F	K	L	M	N																																																				
IEN 1643	73	85	75		5,2	42	60	60	31	7	66	58																																																				
IEN 1653	75	85	75		5,2	43	60	60	32	7	72	64																																																				
IEN 3243	90	95	80	5,2	52	60	70	38	8	78	68																																																					
IEN 3253	92	95	80	5,2	53	60	70	39	8	84	70																																																					
16	400		IEN 1653																																																													
32	400		IEN 3243																																																													
32	400		IEN 3253																																																													

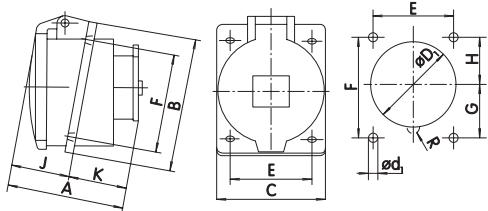
Current [A]	Voltage [V]	Pole / hour angle	Type	Built-in socket IE																																																																																				
IP 44																																																																																								
16	230		IE 1632	  <table border="1"> <thead> <tr> <th>Type \ [mm]</th> <th>A</th> <th>B</th> <th>C</th> <th>ØD₁</th> <th>Ød₁</th> <th>E</th> <th>F</th> <th>G</th> <th>H</th> <th>J</th> <th>K</th> </tr> </thead> <tbody> <tr> <td>IE 1632</td> <td>61</td> <td>85</td> <td>75</td> <td>56</td> <td>5,5</td> <td>60</td> <td>60</td> <td>30</td> <td>30</td> <td>32</td> <td>29</td> </tr> <tr> <td>IE 164x</td> <td>72</td> <td>85</td> <td>75</td> <td>62</td> <td>5,5</td> <td>60</td> <td>60</td> <td>31</td> <td>29</td> <td>33</td> <td>39</td> </tr> <tr> <td>IE 1653</td> <td>73</td> <td>85</td> <td>75</td> <td>65</td> <td>5,5</td> <td>60</td> <td>60</td> <td>31</td> <td>29</td> <td>34</td> <td>39</td> </tr> <tr> <td>IE 3232</td> <td>84</td> <td>95</td> <td>80</td> <td>68</td> <td>5,5</td> <td>60</td> <td>70</td> <td>38</td> <td>32</td> <td>42</td> <td>42</td> </tr> <tr> <td>IE 324x</td> <td>84</td> <td>95</td> <td>80</td> <td>68</td> <td>5,5</td> <td>60</td> <td>70</td> <td>38</td> <td>32</td> <td>42</td> <td>42</td> </tr> <tr> <td>IE 3253</td> <td>84</td> <td>95</td> <td>80</td> <td>74</td> <td>5,5</td> <td>60</td> <td>70</td> <td>36</td> <td>34</td> <td>42</td> <td>42</td> </tr> </tbody> </table>	Type \ [mm]	A	B	C	ØD ₁	Ød ₁	E	F	G	H	J	K	IE 1632	61	85	75	56	5,5	60	60	30	30	32	29	IE 164x	72	85	75	62	5,5	60	60	31	29	33	39	IE 1653	73	85	75	65	5,5	60	60	31	29	34	39	IE 3232	84	95	80	68	5,5	60	70	38	32	42	42	IE 324x	84	95	80	68	5,5	60	70	38	32	42	42	IE 3253	84	95	80	74	5,5	60	70	36	34	42	42
Type \ [mm]	A	B	C		ØD ₁	Ød ₁	E	F	G	H	J	K																																																																												
IE 1632	61	85	75		56	5,5	60	60	30	30	32	29																																																																												
IE 164x	72	85	75		62	5,5	60	60	31	29	33	39																																																																												
IE 1653	73	85	75		65	5,5	60	60	31	29	34	39																																																																												
IE 3232	84	95	80		68	5,5	60	70	38	32	42	42																																																																												
IE 324x	84	95	80		68	5,5	60	70	38	32	42	42																																																																												
IE 3253	84	95	80		74	5,5	60	70	36	34	42	42																																																																												
16	400		IE 1643																																																																																					
16	400		IE 1653																																																																																					
16	500		IE 1645																																																																																					
32	230		IE 3232																																																																																					
32	400		IE 3243																																																																																					
32	400		IE 3253																																																																																					
32	500		IE 3245																																																																																					

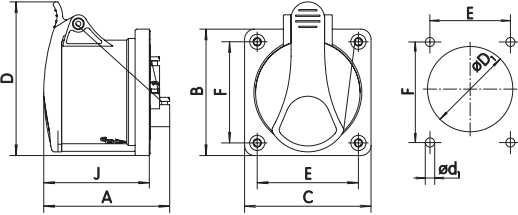
Current [A]	Voltage [V]	Pole / hour angle	Type	Built-in socket IERN – Twiggy																																																		
IP 54																																																						
16	400		IERN 1643	  <table border="1"> <thead> <tr> <th>Type \ [mm]</th> <th>A</th> <th>B</th> <th>C</th> <th>ØD₁</th> <th>Ød₁</th> <th>D</th> <th>E</th> <th>F</th> <th>J</th> </tr> </thead> <tbody> <tr> <td>IERN 1643</td> <td>76</td> <td>75</td> <td>75</td> <td>57</td> <td>4,2</td> <td>88</td> <td>60</td> <td>60</td> <td>61</td> </tr> <tr> <td>IERN 1653</td> <td>77</td> <td>75</td> <td>75</td> <td>57</td> <td>4,2</td> <td>91</td> <td>60</td> <td>60</td> <td>63</td> </tr> <tr> <td>IERN 3243</td> <td>91</td> <td>75</td> <td>75</td> <td>64</td> <td>4,2</td> <td>96</td> <td>60</td> <td>60</td> <td>71</td> </tr> <tr> <td>IERN 3253</td> <td>93</td> <td>75</td> <td>75</td> <td>64</td> <td>4,2</td> <td>103</td> <td>60</td> <td>60</td> <td>75</td> </tr> </tbody> </table>	Type \ [mm]	A	B	C	ØD ₁	Ød ₁	D	E	F	J	IERN 1643	76	75	75	57	4,2	88	60	60	61	IERN 1653	77	75	75	57	4,2	91	60	60	63	IERN 3243	91	75	75	64	4,2	96	60	60	71	IERN 3253	93	75	75	64	4,2	103	60	60	75
Type \ [mm]	A	B	C		ØD ₁	Ød ₁	D	E	F	J																																												
IERN 1643	76	75	75		57	4,2	88	60	60	61																																												
IERN 1653	77	75	75		57	4,2	91	60	60	63																																												
IERN 3243	91	75	75		64	4,2	96	60	60	71																																												
IERN 3253	93	75	75	64	4,2	103	60	60	75																																													
16	400		IERN 1653																																																			
32	400		IERN 3243																																																			
32	400		IERN 3253																																																			

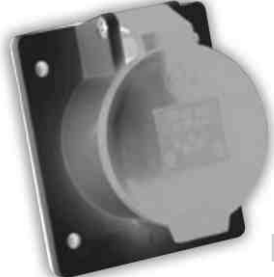
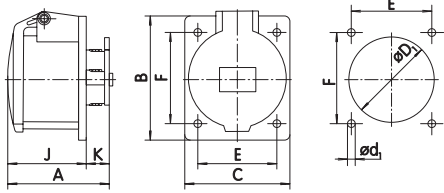
Current [A]	Voltage [V]	Pole / hour angle	Type	Built-in socket IER																														
IP 44																																		
16	400		IER 1643	  <table border="1"> <thead> <tr> <th>Type \ [mm]</th> <th>A</th> <th>B</th> <th>C</th> <th>ØD₁</th> <th>Ød₁</th> <th>E</th> <th>F</th> <th>J</th> <th>K</th> </tr> </thead> <tbody> <tr> <td>IER 1643</td> <td>66,5</td> <td>85</td> <td>75</td> <td>55</td> <td>5,5</td> <td>60</td> <td>60</td> <td>49</td> <td>17,5</td> </tr> <tr> <td>IER 3243</td> <td>78,5</td> <td>95</td> <td>80</td> <td>58</td> <td>5,5</td> <td>60</td> <td>70</td> <td>61</td> <td>17,5</td> </tr> </tbody> </table>	Type \ [mm]	A	B	C	ØD ₁	Ød ₁	E	F	J	K	IER 1643	66,5	85	75	55	5,5	60	60	49	17,5	IER 3243	78,5	95	80	58	5,5	60	70	61	17,5
Type \ [mm]	A	B	C		ØD ₁	Ød ₁	E	F	J	K																								
IER 1643	66,5	85	75	55	5,5	60	60	49	17,5																									
IER 3243	78,5	95	80	58	5,5	60	70	61	17,5																									
32	400		IER 3243																															

INDUSTRIAL SOCKETS AND PLUGS

Socket with a box beneath the plaster IZV

Current [A]	Voltage [V]	Pole / hour angle	Type
16	250		IZV 16
16	250		IZV 16S
16	400		IZV 1643
16	400		IZV 1653
32	400		IZV 3243
32	400		IZV 3253

IP 44

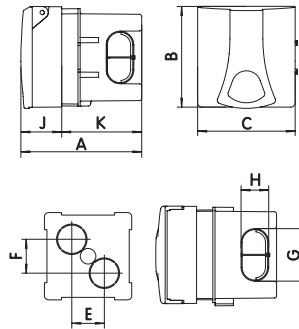

In case of multiple parallel connection of sockets, use connecting element PR 10

Type \ [mm]	A	B	C	E	F	G	H	J	K
IZV xxxx	115,5	93	90	30	30	48,5	25,5	37,7	73,8

16	250		IZVN 16
16	250		IZVN 16S
16	400		IZVN 1643
16	400		IZVN 1653
32	400		IZVN 3243
32	400		IZVN 3253

Socket with a box beneath the plaster IZVN

IP 44

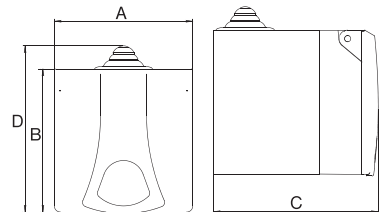

Type \ [mm]	A	B	C	D
IZVN 16	90	93	106	108
IZVN 16S	90	93	106	108
IZVN 1643	90	93	106	108
IZVN 1653	90	93	106	108
IZVN 3243	90	93	106	108
IZVN 3253	90	93	106	108

16	250		IZVN/M16
16	250		IZVN/M16S
16	400		IZVN/M1643
16	400		IZVN/M1653
32	400		IZVN/M3243
32	400		IZVN/M3253

Socket with a box beneath the plaster IZVN/M

IP 44

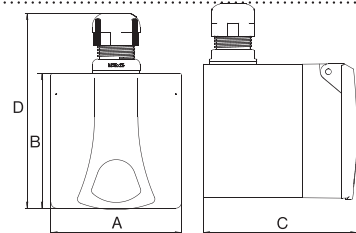

Type \ [mm]	A	B	C	D
IZVN/M 16	90	93	106	134
IZVN/M 16S	90	93	106	134
IZVN/M 1643	90	93	106	134
IZVN/M 1653	90	93	106	134
IZVN/M 3243	90	93	106	134
IZVN/M 3253	90	93	106	134

16	230		IEG 1632
16	400		IEG 1643
16	400		IEG 1653
32	230		IEG 3232
32	400		IEG 3243
32	400		IEG 3253

Built-in socket IEG

IP 67

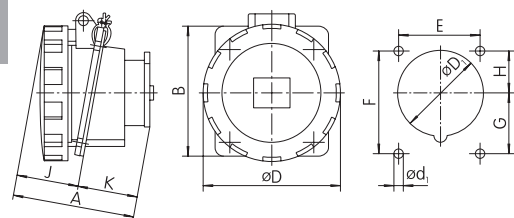

Type \ [mm]	A	B	ØD	ØD1	Ød	E	F	G	H	J	K
IEG 1632	78	85	75	56	5,5	60	60	30	30	39	39
IEG 1643	80	85	78	62	5,5	60	60	31	29	41	39
IEG 1653	81	85	87	65	5,5	60	60	31	29	42	39
IEG 3232	89	95	92,5	68	5,5	60	70	38	32	47	42
IEG 3243	89	95	92,5	68	5,5	60	70	38	32	47	42
IEG 3253	91	95	100	74	5,5	60	70	36	34	49	42

INDUSTRIAL SOCKETS AND PLUGS

Current [A]	Voltage [V]	Pole / hour angle	Type	Built-in socket IEGN – Twiggy
-------------	-------------	-------------------	------	-------------------------------

IP 67

63 400  IEGN 6353

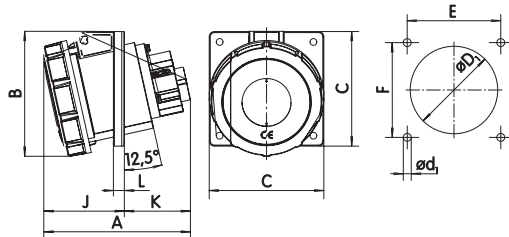
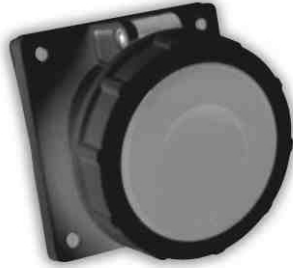

Type \ [mm]	A	B	C	Ød ₁	ØD ₁	E	F	J	K	L
IEGN 6353	145	120	110	6,5	95	90	90	80	65	10,5

125 230  IEGN 12532

Built-in socket IEGN

IP 67

125 400  IEGN 12543

125 400  IEGN 12553

125 500  IEGN 12545

125 500  IEGN 12555

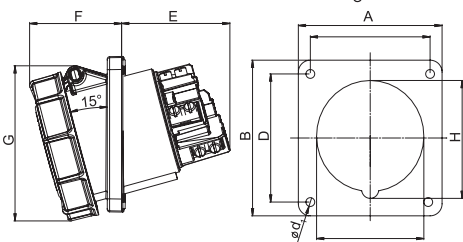

Type \ [mm]	A	B	C	D	E	F	G	H	J	Ød ₁
IEGN 12532	114	114	90	90	92	77	130	102	90	7
IEGN 12543	114	114	90	90	92	77	130	102	90	7
IEGN 12553	114	114	90	90	92	77	130	102	90	7
IEGN 12545	114	114	90	90	92	77	130	102	90	7
IEGN 12555	114	114	90	90	92	77	130	102	90	7

125 230  IEGN 12532-p

Built-in socket IEGN with a pilot contact

IP 67

125 400  IEGN 12543-p

125 400  IEGN 12553-p

125 500  IEGN 12545-p

125 500  IEGN 12555-p

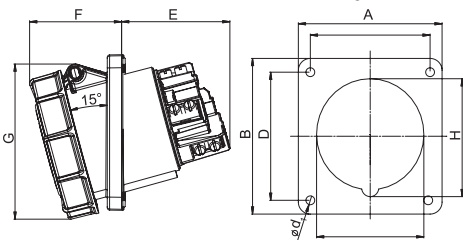
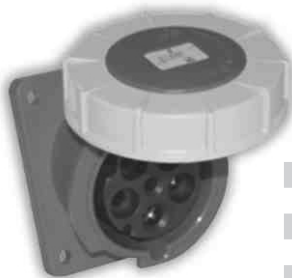

Type \ [mm]	A	B	C	D	E	F	G	H	J	Ød ₁
IEGN 12532-p	114	114	90	90	92	77	130	102	90	7
IEGN 12543-p	114	114	90	90	92	77	130	102	90	7
IEGN 12553-p	114	114	90	90	92	77	130	102	90	7
IEGN 12545-p	114	114	90	90	92	77	130	102	90	7
IEGN 12555-p	114	114	90	90	92	77	130	102	90	7

Built-in socket IEG

IP 67

63 400  IEG 6343

63 500  IEG 6345

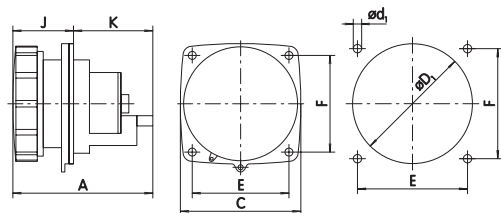
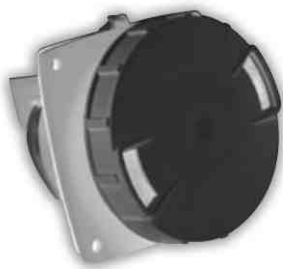

Type \ [mm]	A	C	Ød ₁	ØD ₁	E	F	J	K
IEG 634x	131	111	6,8	93	90	90	52	79

INDUSTRIAL SOCKETS AND PLUGS

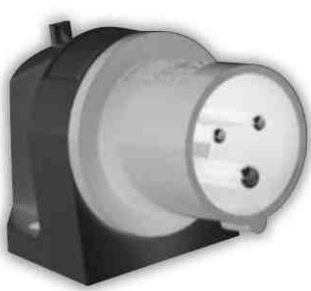
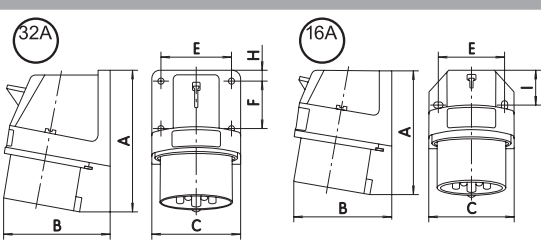

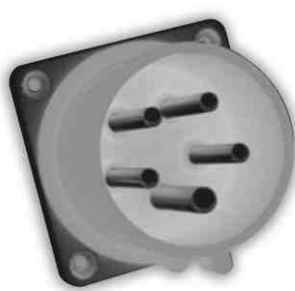
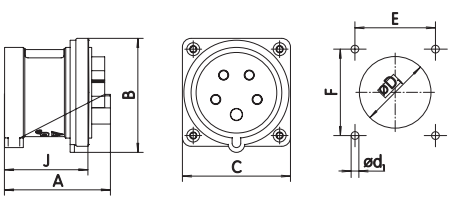

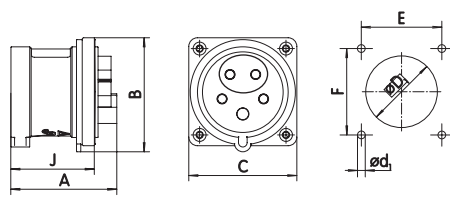

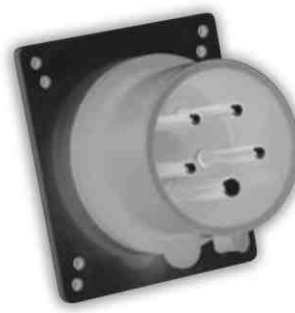
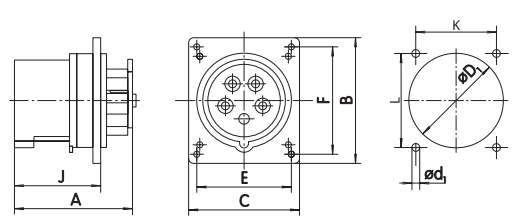
Current [A]	Voltage [V]	Pole / hour angle	Type	Built-in appliance inlet IR																																																	
16	230		IR 1632	 <p>IP 44</p>  <table border="1"> <thead> <tr> <th>Type \ [mm]</th> <th>A</th> <th>B</th> <th>C</th> <th>E</th> <th>F</th> <th>I</th> </tr> </thead> <tbody> <tr> <td>IR 1632</td> <td>91</td> <td>68</td> <td>57,2</td> <td>45</td> <td></td> <td>20</td> </tr> <tr> <td>IR 164x</td> <td>97</td> <td>77</td> <td>65,2</td> <td>50</td> <td></td> <td>27,5</td> </tr> <tr> <td>IR 1653</td> <td>98</td> <td>79</td> <td>65,2</td> <td>50</td> <td></td> <td>27,5</td> </tr> <tr> <td>IR 3232</td> <td>128</td> <td>88</td> <td>72,5</td> <td>58</td> <td>40</td> <td>9</td> </tr> <tr> <td>IR 324x</td> <td>128</td> <td>88</td> <td>72,3</td> <td>58</td> <td>40</td> <td>9</td> </tr> <tr> <td>IR 3253</td> <td>129</td> <td>90</td> <td>72,3</td> <td>58</td> <td>40</td> <td>9</td> </tr> </tbody> </table>	Type \ [mm]	A	B	C	E	F	I	IR 1632	91	68	57,2	45		20	IR 164x	97	77	65,2	50		27,5	IR 1653	98	79	65,2	50		27,5	IR 3232	128	88	72,5	58	40	9	IR 324x	128	88	72,3	58	40	9	IR 3253	129	90	72,3	58	40	9
Type \ [mm]	A	B	C		E	F	I																																														
IR 1632	91	68	57,2		45		20																																														
IR 164x	97	77	65,2		50		27,5																																														
IR 1653	98	79	65,2		50		27,5																																														
IR 3232	128	88	72,5		58	40	9																																														
IR 324x	128	88	72,3	58	40	9																																															
IR 3253	129	90	72,3	58	40	9																																															
16	400		IR 1643																																																		
16	400		IR 1653																																																		
32	230		IR 3232																																																		
32	400		IR 3243																																																		
32	400		IR 3253																																																		

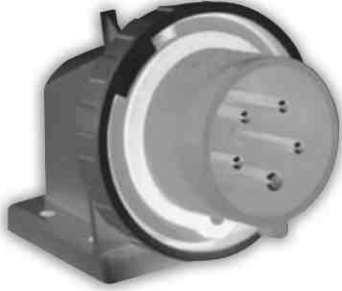
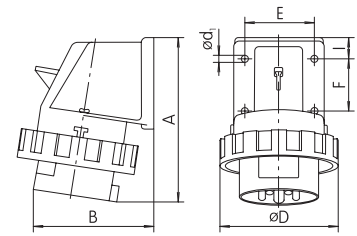

Current [A]	Voltage [V]	Pole / hour angle	Type	Built-in appliance inlet straight IRRN – Twiggy																																													
16	400		IRRN 1643	 <p>IP 44</p>  <table border="1"> <thead> <tr> <th>Type \ [mm]</th> <th>A</th> <th>B</th> <th>C</th> <th>Ød₁</th> <th>ØD₁</th> <th>E</th> <th>F</th> <th>J</th> </tr> </thead> <tbody> <tr> <td>IRRN 1643</td> <td>66</td> <td>75</td> <td>75</td> <td>4,2</td> <td>57</td> <td>60</td> <td>60</td> <td>48</td> </tr> <tr> <td>IRRN 1653</td> <td>66</td> <td>75</td> <td>75</td> <td>4,2</td> <td>57</td> <td>60</td> <td>60</td> <td>48</td> </tr> <tr> <td>IRRN 3243</td> <td>73</td> <td>75,3</td> <td>75</td> <td>4,2</td> <td>64</td> <td>60</td> <td>60</td> <td>58</td> </tr> <tr> <td>IRRN 3253</td> <td>73</td> <td>80</td> <td>75</td> <td>4,2</td> <td>64</td> <td>60</td> <td>60</td> <td>58</td> </tr> </tbody> </table>	Type \ [mm]	A	B	C	Ød ₁	ØD ₁	E	F	J	IRRN 1643	66	75	75	4,2	57	60	60	48	IRRN 1653	66	75	75	4,2	57	60	60	48	IRRN 3243	73	75,3	75	4,2	64	60	60	58	IRRN 3253	73	80	75	4,2	64	60	60	58
Type \ [mm]	A	B	C		Ød ₁	ØD ₁	E	F	J																																								
IRRN 1643	66	75	75		4,2	57	60	60	48																																								
IRRN 1653	66	75	75		4,2	57	60	60	48																																								
IRRN 3243	73	75,3	75	4,2	64	60	60	58																																									
IRRN 3253	73	80	75	4,2	64	60	60	58																																									
16	400		IRRN 1653																																														
32	400		IRRN 3243																																														
32	400		IRRN 3253																																														





Current [A]	Voltage [V]	Pole / hour angle	Type	Built-in appliance inlet straight reversing IRRNO – Twiggy																											
16	400		IRRNO 1653	 <p>IP 44</p>  <table border="1"> <thead> <tr> <th>Type \ [mm]</th> <th>A</th> <th>B</th> <th>C</th> <th>Ød₁</th> <th>ØD₁</th> <th>E</th> <th>F</th> <th>J</th> </tr> </thead> <tbody> <tr> <td>IRRNO 1653</td> <td>66</td> <td>75</td> <td>75</td> <td>4,2</td> <td>57</td> <td>60</td> <td>60</td> <td>48</td> </tr> <tr> <td>IRRNO 3253</td> <td>73</td> <td>80</td> <td>75</td> <td>4,2</td> <td>64</td> <td>60</td> <td>60</td> <td>58</td> </tr> </tbody> </table>	Type \ [mm]	A	B	C	Ød ₁	ØD ₁	E	F	J	IRRNO 1653	66	75	75	4,2	57	60	60	48	IRRNO 3253	73	80	75	4,2	64	60	60	58
Type \ [mm]	A	B	C		Ød ₁	ØD ₁	E	F	J																						
IRRNO 1653	66	75	75		4,2	57	60	60	48																						
IRRNO 3253	73	80	75	4,2	64	60	60	58																							
32	400		IRRNO 3253																												

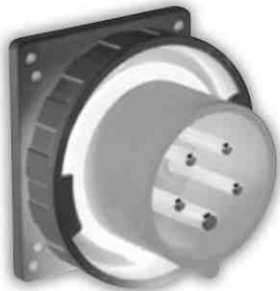
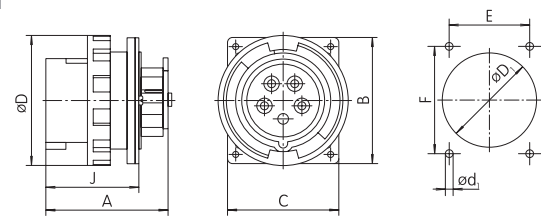



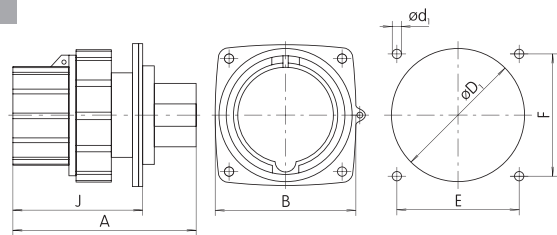

Current [A]	Voltage [V]	Pole / hour angle	Type	Built-in appliance inlet straight IRR																																	
16	400		IRR 1653	 <p>IP 44</p>  <table border="1"> <thead> <tr> <th>Type \ [mm]</th> <th>A</th> <th>B</th> <th>C</th> <th>Ød₁</th> <th>ØD₁</th> <th>E</th> <th>F</th> <th>J</th> <th>K</th> <th>L</th> </tr> </thead> <tbody> <tr> <td>IRR 1653</td> <td>80</td> <td>85</td> <td>75</td> <td>4,3</td> <td>65</td> <td>64</td> <td>73</td> <td>58</td> <td>60</td> <td>60</td> </tr> <tr> <td>IRR 3253</td> <td>96</td> <td>95</td> <td>80</td> <td>5,5</td> <td>71</td> <td>70</td> <td>84</td> <td>72</td> <td>60</td> <td>70</td> </tr> </tbody> </table>	Type \ [mm]	A	B	C	Ød ₁	ØD ₁	E	F	J	K	L	IRR 1653	80	85	75	4,3	65	64	73	58	60	60	IRR 3253	96	95	80	5,5	71	70	84	72	60	70
Type \ [mm]	A	B	C		Ød ₁	ØD ₁	E	F	J	K	L																										
IRR 1653	80	85	75	4,3	65	64	73	58	60	60																											
IRR 3253	96	95	80	5,5	71	70	84	72	60	70																											
32	400		IRR 3253																																		

INDUSTRIAL SOCKETS AND PLUGS

Current [A]	Voltage [V]	Pole / hour angle	Type	Built-in appliance inlet IRG																																																								
IP 67																																																												
16	230		IRG 1632	  <table border="1"> <thead> <tr> <th>Type \ [mm]</th> <th>A</th> <th>B</th> <th>D</th> <th>Ød₁</th> <th>E</th> <th>F</th> <th>I</th> </tr> </thead> <tbody> <tr> <td>IRG 1632</td> <td>114</td> <td>74</td> <td>70</td> <td>4,8</td> <td>45</td> <td>30</td> <td>15</td> </tr> <tr> <td>IRG 1643</td> <td>117</td> <td>83</td> <td>78</td> <td>5,2</td> <td>50</td> <td>30</td> <td>17,5</td> </tr> <tr> <td>IRG 1653</td> <td>119</td> <td>85</td> <td>87</td> <td>5,2</td> <td>50</td> <td>30</td> <td>17,5</td> </tr> <tr> <td>IRG 3232</td> <td>142</td> <td>98</td> <td>92,5</td> <td>5,2</td> <td>58</td> <td>40</td> <td>20</td> </tr> <tr> <td>IRG 3243</td> <td>142</td> <td>98</td> <td>92,5</td> <td>5,2</td> <td>58</td> <td>40</td> <td>20</td> </tr> <tr> <td>IRG 3253</td> <td>142</td> <td>101</td> <td>100</td> <td>5,2</td> <td>58</td> <td>40</td> <td>20</td> </tr> </tbody> </table>	Type \ [mm]	A	B	D	Ød ₁	E	F	I	IRG 1632	114	74	70	4,8	45	30	15	IRG 1643	117	83	78	5,2	50	30	17,5	IRG 1653	119	85	87	5,2	50	30	17,5	IRG 3232	142	98	92,5	5,2	58	40	20	IRG 3243	142	98	92,5	5,2	58	40	20	IRG 3253	142	101	100	5,2	58	40	20
Type \ [mm]	A	B	D		Ød ₁	E	F	I																																																				
IRG 1632	114	74	70		4,8	45	30	15																																																				
IRG 1643	117	83	78		5,2	50	30	17,5																																																				
IRG 1653	119	85	87		5,2	50	30	17,5																																																				
IRG 3232	142	98	92,5		5,2	58	40	20																																																				
IRG 3243	142	98	92,5	5,2	58	40	20																																																					
IRG 3253	142	101	100	5,2	58	40	20																																																					
16	400		IRG 1643																																																									
16	400		IRG 1653																																																									
32	230		IRG 3232																																																									
32	400		IRG 3243																																																									
32	400		IRG 3253																																																									

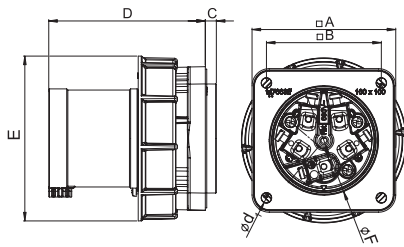
Current [A]	Voltage [V]	Pole / hour angle	Type	Built-in appliance inlet straight IRGR																														
IP 67																																		
16	400		IRGR 1653	  <table border="1"> <thead> <tr> <th>Type \ [mm]</th> <th>A</th> <th>B</th> <th>C</th> <th>Ød₁</th> <th>ØD</th> <th>ØD₁</th> <th>E</th> <th>F</th> <th>J</th> </tr> </thead> <tbody> <tr> <td>IRGR 1653</td> <td>80,5</td> <td>85</td> <td>75</td> <td>4</td> <td>87</td> <td>65</td> <td>64</td> <td>73</td> <td>59</td> </tr> <tr> <td>IRGR 3253</td> <td>96</td> <td>95</td> <td>80</td> <td>4</td> <td>100</td> <td>71</td> <td>70</td> <td>84</td> <td>72</td> </tr> </tbody> </table>	Type \ [mm]	A	B	C	Ød ₁	ØD	ØD ₁	E	F	J	IRGR 1653	80,5	85	75	4	87	65	64	73	59	IRGR 3253	96	95	80	4	100	71	70	84	72
Type \ [mm]	A	B	C		Ød ₁	ØD	ØD ₁	E	F	J																								
IRGR 1653	80,5	85	75	4	87	65	64	73	59																									
IRGR 3253	96	95	80	4	100	71	70	84	72																									
32	400		IRGR 3253																															

Current [A]	Voltage [V]	Pole / hour angle	Type	Built-in appliance inlet straight IRG																								
IP 67																												
63	400		IRG 6343	  <table border="1"> <thead> <tr> <th>Type \ [mm]</th> <th>A</th> <th>B</th> <th>Ød₁</th> <th>ØD₁</th> <th>E</th> <th>F</th> <th>J</th> </tr> </thead> <tbody> <tr> <td>IRG 6343</td> <td>113</td> <td>111</td> <td>6,8</td> <td>75</td> <td>90</td> <td>90</td> <td>90</td> </tr> <tr> <td>IRG 12543</td> <td>124</td> <td>130</td> <td>6,8</td> <td>92</td> <td>106</td> <td>106</td> <td>106</td> </tr> </tbody> </table>	Type \ [mm]	A	B	Ød ₁	ØD ₁	E	F	J	IRG 6343	113	111	6,8	75	90	90	90	IRG 12543	124	130	6,8	92	106	106	106
Type \ [mm]	A	B	Ød ₁		ØD ₁	E	F	J																				
IRG 6343	113	111	6,8	75	90	90	90																					
IRG 12543	124	130	6,8	92	106	106	106																					
125	400		IRG 12543																									

Current [A]	Voltage [V]	Pole / hour angle	Type	Built-in appliance inlet straight IRGN																																																
IP 67																																																				
125	230		IRGN 12532	  <table border="1"> <thead> <tr> <th>Type \ [mm]</th> <th>AxA</th> <th>BxB</th> <th>C</th> <th>D</th> <th>E</th> <th>øF</th> <th>ød₁</th> </tr> </thead> <tbody> <tr> <td>IRGN 12532</td> <td>120</td> <td>100</td> <td>13</td> <td>118</td> <td>131</td> <td>95</td> <td>7</td> </tr> <tr> <td>IRGN 12543</td> <td>120</td> <td>100</td> <td>13</td> <td>118</td> <td>131</td> <td>95</td> <td>7</td> </tr> <tr> <td>IRGN 12553</td> <td>120</td> <td>100</td> <td>13</td> <td>118</td> <td>131</td> <td>95</td> <td>7</td> </tr> <tr> <td>IRGN 12545</td> <td>120</td> <td>100</td> <td>13</td> <td>118</td> <td>131</td> <td>95</td> <td>7</td> </tr> <tr> <td>IRGN 12555</td> <td>120</td> <td>100</td> <td>13</td> <td>118</td> <td>131</td> <td>95</td> <td>7</td> </tr> </tbody> </table>	Type \ [mm]	AxA	BxB	C	D	E	øF	ød ₁	IRGN 12532	120	100	13	118	131	95	7	IRGN 12543	120	100	13	118	131	95	7	IRGN 12553	120	100	13	118	131	95	7	IRGN 12545	120	100	13	118	131	95	7	IRGN 12555	120	100	13	118	131	95	7
Type \ [mm]	AxA	BxB	C		D	E	øF	ød ₁																																												
IRGN 12532	120	100	13		118	131	95	7																																												
IRGN 12543	120	100	13		118	131	95	7																																												
IRGN 12553	120	100	13		118	131	95	7																																												
IRGN 12545	120	100	13		118	131	95	7																																												
IRGN 12555	120	100	13	118	131	95	7																																													
125	400		IRGN 12543																																																	
125	400		IRGN 12553																																																	
125	500		IRGN 12545																																																	
125	500		IRGN 12555																																																	

INDUSTRIAL SOCKETS AND PLUGS

Current [A]	Voltage [V]	Pole / hour angle	Type	Reversing adapter RA
-------------	-------------	-------------------	------	----------------------

IP 44

16 400  RA 1643

16 400  RA 1653

32 400  RA 3243

32 400  RA 3253

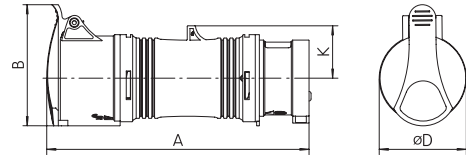

Type \ [mm]	A	B	ØD	K
RA 1643	178	82	56	35
RA 1653	180	89	64	39
RA 3243	235	96	65	41
RA 3253	237	104	73	45

Adapter A 5p/4p

IP 44

16 400 
 A 1653/43

32 400 
 A 3253/43



The use of the adapter A5p/ 4p-0 is conditioned by the symmetrical load since the 4-pole socket connection is 3P+PE.

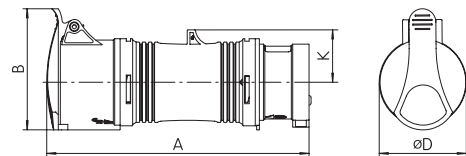

Type \ [mm]	A	B	ØD	K
A 1653/43	180	82	64	39
A 3253/43	235	96	73	45

Adapter with reversing A 5p/4p-0

IP 44

16 400 
 A 1653/43-0

32 400 
 A 3253/43-0



The use of the adapter A5p/ 4p-0 is conditioned by the symmetrical load since the 4-pole socket connection is 3P+PE.

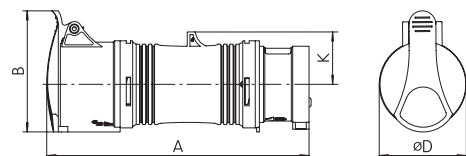

Type \ [mm]	A	B	ØD	K
A 1653/43-0	180	82	64	39
A 3253/43-0	235	96	73	45

Adapter A 16-32/x

IP 44

16 400  A 16-32/4

32 400  A 16-32/5

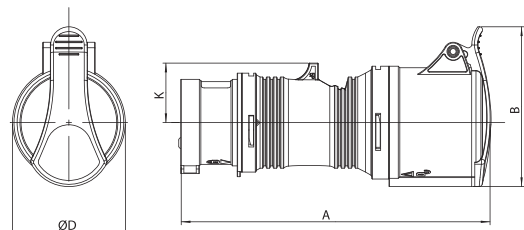

Type \ [mm]	A	B	ØD	K
A 16-32/4	198	96	65	34
A 16-32/5	200	103	73	37

TEKNIC

INDUSTRIAL SOCKETS AND PLUGS

Current [A]	Voltage [V]	Pole / hour angle	Type	Adapter with reversing A 16-32/5-0
-------------	-------------	-------------------	------	------------------------------------

IP 44

16 400  A 16-32/5-0

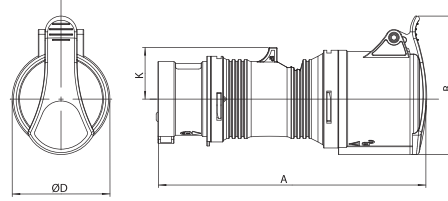

Type \ [mm]	A	B	ØD	K
A 16-32/5	200	103	73	37

Cable adapters SAx



Picture 1

Picture 2

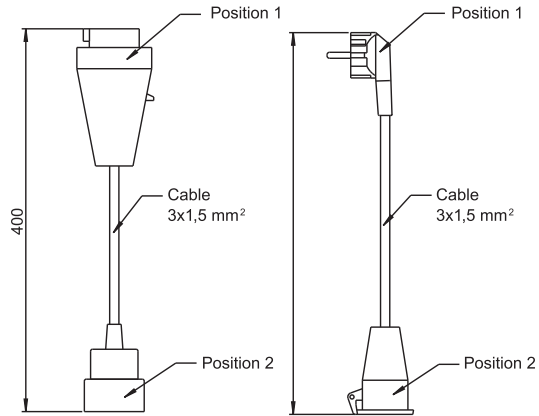

Type \ [mm]	Picture	REDUCTION	
		FROM POSITION 1	TO POSITION 2
SA-1	1	Industrial plug IV 1632 3P 16A/250V~	House socket 16A/250V~
SA-1S	1	Industrial plug IV 1632 3P 16A/250V~	House socket SCHUKO 16A/250V~
SA-2	1	Industrial plug IVN 1653 5P 16A/3x400V~	House socket 16A/250V~
SA-2S	1	Industrial plug IVN 1653 5P 16A/3x400V~	House socket SCHUKO 16A/250V~
SA-3	2	House plug UNISCHUKO16A/250V~	Industrial socket IS 1632 3P 16A/250V~
SA-4	2	House plug UNISCHUKO16A/250V~	Industrial socket IS 3232 3P 32A/250V~

Built-in socket VZ

IP 54

16 250  VZ 16

16 250  VZ 16 S

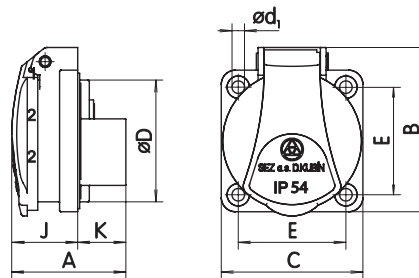

Type \ [mm]	A	B	C	ØD	Ød ₁	E	J	K
VZ 16	40,3	59,5	50	43	4,5	38	23,3	17
VZ 16 S	43	59,5	50	43	4,5	38	26	17

INDUSTRIAL SOCKETS AND PLUGS

Current [A]	Voltage [V]	Pole / hour angle	Type	Built-in socket VZG
-------------	-------------	-------------------	------	---------------------

IP 67

16 250  VZG 16

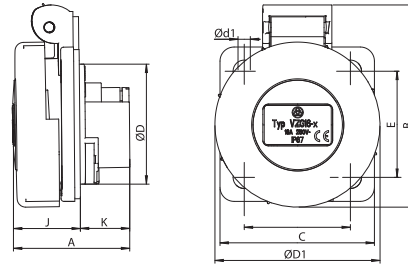

16 250  VZG 16 S

Type \ [mm]	A	B	C	ØD	Ød1	E	J	K	
VZG 16	42	73	55	43	4,5	38	24	18	60
VZG 16 S	48	73	55	43	4,5	38	24	24	60

Plug UNI-SCHUKO PVG 16

When protected in IP67, plug PVG 16 is compatible with built-in sockets VZG 16, VZG 16C, VZG 16S.

IP 67

16 250  PVG 16

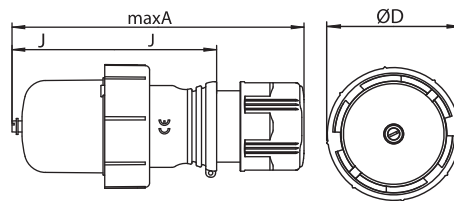

Type \ [mm]	max A	J	ØD
PVG 16	137	96	58

Built-in socket VZ 48

ČSN 35 4517

10 48  VZ 48

IP 54



It is possible to insert the fat plug pin inlets 10A/48V into this socket, which is in accordance with the norm ČSN 35 4517 modification "K" (2P). VZ 48 socket can also be used in case of lower voltage, i.e. 24 V or 12 V. For that case it is necessary to add an extra label where real voltage is written!

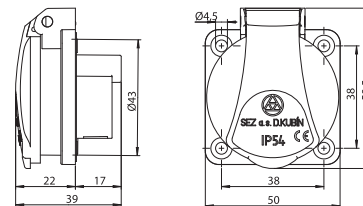

Type \ [mm]	A	B	C	ØD	Ød	E	J	K
VZ 48	39	59,5	50	43	4,5	38	22	17

Interlocked switch with socket outlet BZS



The switch cannot be turned on without inserted plug.

The plug cannot be pulled out when the switch is on.

16 400  BZS 1653

IP 44

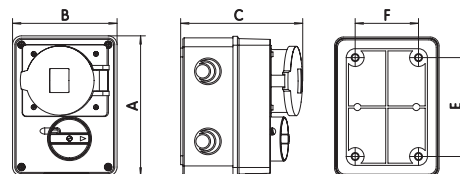

32 400  BZS 3253

Type \ [mm]	A	B	C	E	F
BZS 1653	157,5	117,5	129	112	72
BZS 3253	157,5	117,5	137	112	72

INDUSTRIAL SOCKETS AND PLUGS

Current [A]	Voltage [V]	Pole / hour angle	Type	Interlocked switch with socket outlet VPS
-------------	-------------	-------------------	------	---

IP 44

16 400  VPS 1653

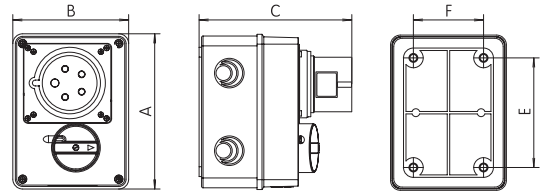

32 400  VPS 3253

Type \ [mm]	A	B	C	E	F
VPS 1653	157,5	117,5	153,8	112	72
VPS 3253	157,5	117,5	165	112	72

Lid KV

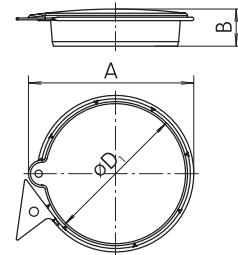
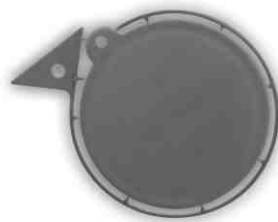

Type \ [mm]	A	B	ØD
KV 1643	54,7	16,1	49,5
KV 1653	62,1	16,2	56,1
KV 3243	63,3	16,2	57,3
KV 3253	70	16,4	63,4

Cover

IP 67

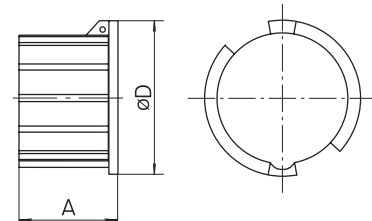

Type \ [mm]	Ordering number	A	ØD
CPG 1632	ND105-0757	39,5	60
IVG/IPG 634x, IRG 6343	ND 63CPG1	70,5	95,5
IVG/IPG 1643	ND 16CPG1	N/A	N/A
IEG 1643	ND 16CZG1	N/A	N/A
IEG 3243	ND 32CZG1	N/A	N/A
ISG 634x	ND 63CZG1	N/A	N/A

Covers are available only in gray colour.

Fixing frame ND 105-2677

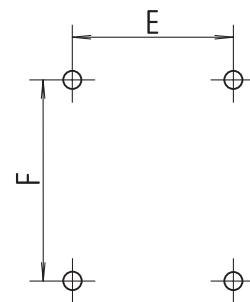

When mounting use a screw for plastic materials Ø4 mm.

Type \ [mm]	E	F
ND 105-2677	38	38

For the built-in socket VZ 16 and VZ 16 S.

INDUSTRIAL SOCKETS AND PLUGS

Current [A]	Voltage [V]	Pole / hour angle	Type	Fixing frame ND 105-2177
-------------	-------------	-------------------	------	--------------------------

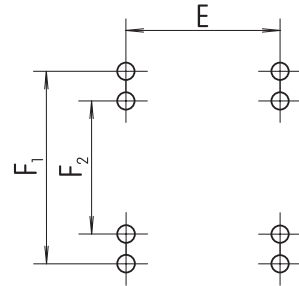
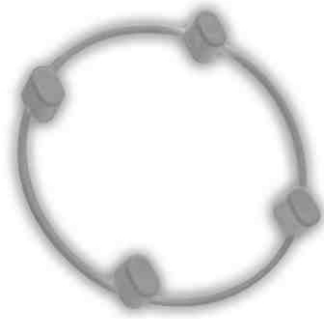

When mounting use a screw for plastic materials $\varnothing 4$ mm.

Type \ [mm]	E	F ₁	F ₂
ND 105-2177	60	70	60

For all types of built-in sockets IEN, IE a IERN.

Connecting element PR 10

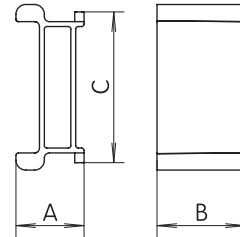

To be used for: 6400-5x
IZV 16
IZV xxxx

Type \ [mm]	A	B	C
PR 10	13,9	18	30,8

Flange SPg16

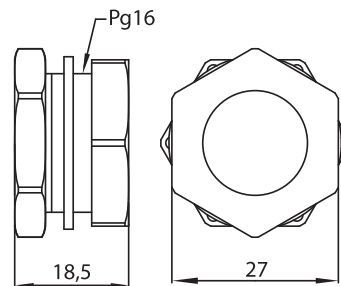

To be used for the connection of : IZVN xxxx
IZVN/M xxxx

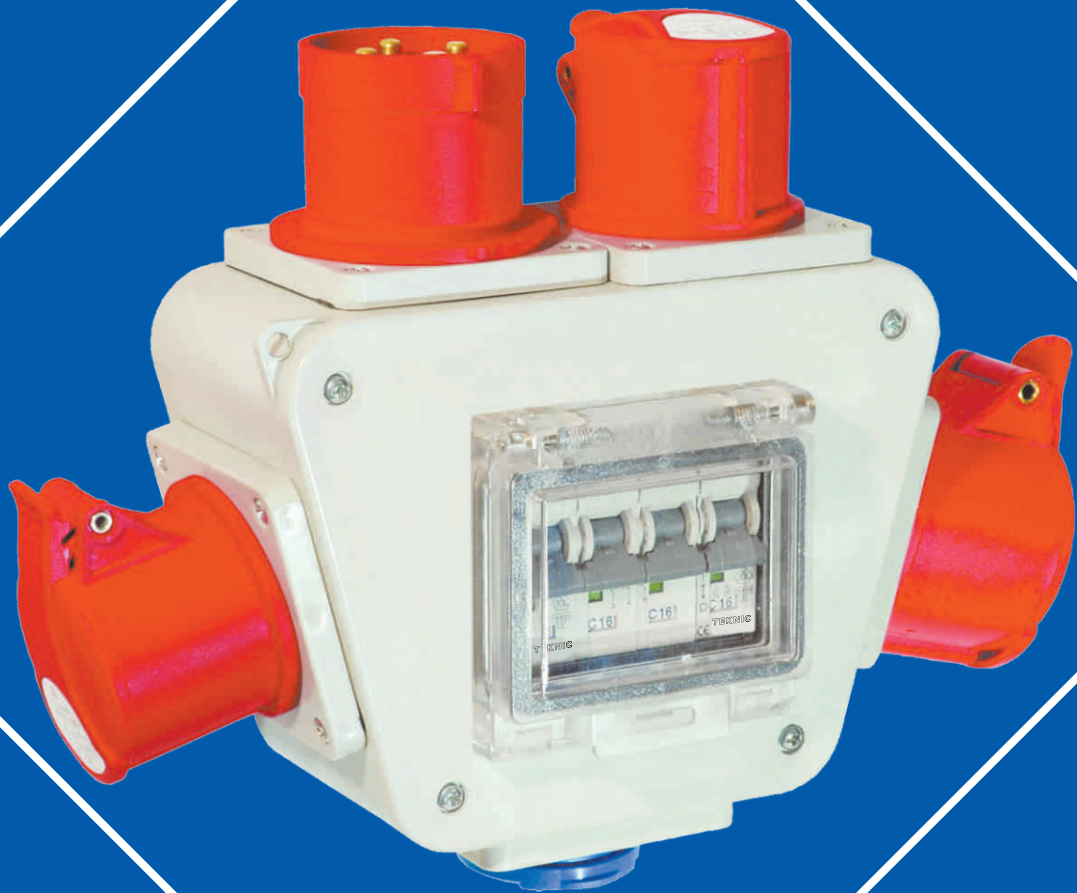

TEKNIC